

Brabender Loss-in-Weight Feeder DDW-MD6-DDSR40B-100(200)

The Brabender DDW-MD6-DDSR40B-100(200) loss-in-weight feeder, the gravimetric version of the Brabender DDSR40B twin screw feeder, is capable of reliably and accurately metering extremely difficult flowing bulk ingredients with temperatures from 0 to 60°C (32-140°F) at medium feed rates. The feeder has the following main components: a free-standing mounting base/scale with a digital load cell ("DigiMASS-2"), a Brabender twin screw feeder DDSR40B with a horizontal stirring agitator in the screw trough, and an extension hopper for ingredient storage. The DigiMASS-2 load cell has the following features: a theoretical resolution of 4,000,000:1, twin vibrating wire technology which compensates for temperature change and external vibration, filtering software, and a serial interface ensuring high-speed data communication. The twin screw feeder provides mass flow of ingredient and consistent screw filling since the stirring

agitator prevents bridging and promotes ingredient flow into the screw. The feeder has a particularly large ingredient inlet. Together with a straight walled 100 dm³ (3.5 ft³) or steep sided 200 dm³ (7.1 ft³) extension hopper and the stirring agitator it provides reliable mass flow even with ingredients that would otherwise require mechanical agitation in the extension hopper. All components are fully mounted and wired to junction boxes. Options include versions with onboard control / speed control electronics ("ISC plus") and interchangeable twin screws. Ingredient contact steel parts are made of stainless steel. Mild steel parts are painted light grey (RAL 7035). Environmental conditions: 0-45°C (32-113°F), up to 85% humidity without condensation. The feeder conforms to CE directives.

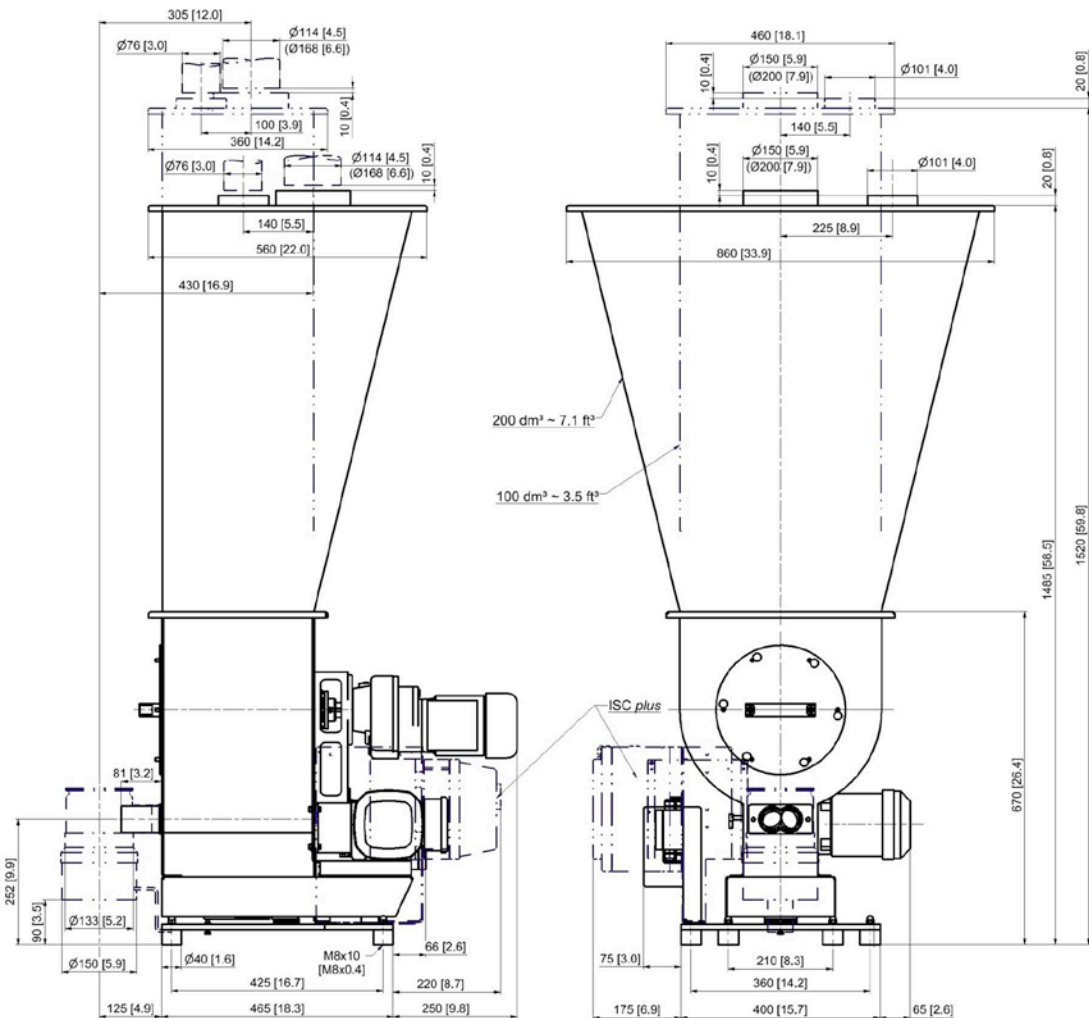

Weight with 100 dm³/3.5 ft³ extension hopper approx. 120 kg (265 lb)

Weight with 200 dm³/7.1 ft³ extension hopper approx. 135 kg (298 lb)

Dimensions in mm (in)

Technical Data

Available screw sizes and feed rates

Screw Type	Ø (mm) x p (mm)	Tube designation	Tube dia. (mm)	Max. speed (rpm)	Max. feed rate (dm ³ /hr)*	Max. feed rate (ft ³ /hr)*
Double Spiral Screw (SS)	SS 33/22	419	48.3 x 3.2	385 / 100Hz	800	28.3
	SS 33/22	470	53.0 x 3.0	385 / 100Hz	1208	42.7
	SS 33/35	419	48.3 x 3.2	385 / 100Hz	1311	46.3
	SS 33/35	470	53.0 x 3.0	385 / 100Hz	1960	69.2
Twin Spiral Screw (TS)	TS 40/27	419	48.3 x 3.2	385 / 100Hz	1384	48.9
	TS 40/27	470	53.0 x 3.0	385 / 100Hz	1671	59.0
	TS 40/42	419	48.3 x 3.2	385 / 100Hz	2247	79.4
	TS 40/42	470	53.0 x 3.0	385 / 100Hz	2693	95.1
Twin Blade Screw (TB)	TB 40/28	419	48.3 x 3.2	385 / 100Hz	1141	40.3
	TB 40/43	419	48.3 x 3.2	385 / 100Hz	1853	65.4
Twin Concave Screw (TC)	TC 40/12	419	48.3 x 3.2	385 / 100Hz	150	5.3
	TC 40/23	419	48.3 x 3.2	385 / 100Hz	288	10.2
	TC 40/27	470	53.0 x 3.0	385 / 100Hz	686	24.2
	TC 40/50	470	53.0 x 3.0	385 / 100Hz	1604	56.6

* Theoretical values at 100% screw filling level and motor speed. Depending on the flow characteristics the screw filling level may decrease to 50%. In addition, max. speed should be reduced to allow for bulk density variations.

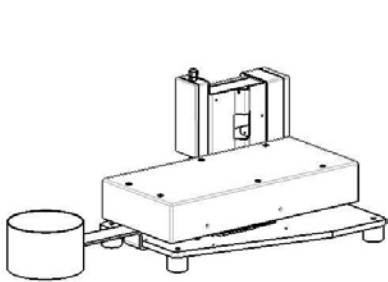

Mounting Base / Scale MD6

- Free-standing mounting base with vibration isolation feet and junction boxes
- Digital load cell DigiMASS-2 (2 vibrating wires)
- Approx. net weighing ranges:
 - 245 kg/540 lb (100 dm³/3.5 ft³ extension hopper)
 - 230 kg/507 lb (200 dm³/7.1 ft³ extension hopper)

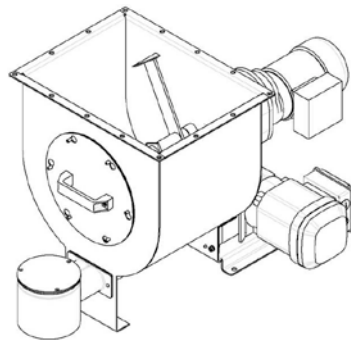

Twin Screw Feeder DDSR40B

- Stainless steel housing
- Exchangeable twin screws
- Variable frequency driven 3 phase AC gear motor (0.37 kW, 230/400 V, IP65, TEFC), screw speed max. 385 rpm/100 Hz
- Horizontal stirring agitator in the screw trough (driven by a separate 3 phase AC motor 0.12 kW, 230/400 V, IP65, TEFC, agitator speed 6.8 rpm/50 Hz)
- Ingredient contact surfaces are stainless steel SS 1.4301 (304)

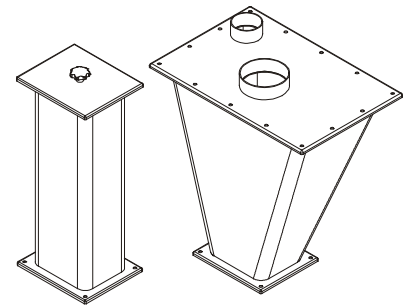

Extension Hoppers

- Extension hoppers
 - 100 dm³ (3.5 ft³), straight walled
 - 200 dm³ (7.1 ft³), steep sided
- Cover with inlet pipe and vent pipe for automatic refill, or
- Lift off cover with handle for manual refill
- Stainless steel SS 1.4301 (304)

Accessories

- Flexible connections
- Exchange twin screws
- Exchange screw tubes
- Safety grate for manual refill
- JetFilter for vent pipe

Options

- Version without discharge connection pipe
- Screw tube without vertical downspout
- Pressure compensation
- Explosion-proof designs
- Designs for higher or lower ingredient and/or ambient temperatures

Controls

Feeder control and speed modules are offered either mounted on the feeder or for mounting in a separate panel. Controls can communicate directly to most host/PLC systems or to Brabender Congrav® Operator Interfaces (see Congrav® Works Standards)



Modifications reserved. All data describe our products in a general manner. They are no agreement on or warranty of characteristics in the sense of § 434 or guarantee in the sense of § 443 of the German Civil Code or similar regulations and effect no liability.

Issue 4.0 (April 16)
Supersedes 8.0 (August 13)